

OPTIMUM QUALITY MAXIMUM RELIABILITY™



CT20U

SEMI-AUTOMATIC CASE TAPER



Incorporating the latest case taping technology, the CT20U Case Taper combines excellent performance and value for money.



CT20U

SEMI-AUTOMATIC CASE TAPER

Features include:

- > Optimax-quality engineering at an affordable price
- > Simple use and maintenance
- > Seals 150 - 500mm wide and 120 - 500mm high cartons
- > Outfeed and infeed conveyors as standard
- > Braking swivel castors
- > Adjustable table height option
- > Reliable, energy efficient operation



Maximum/minimum carton dimensions capacity

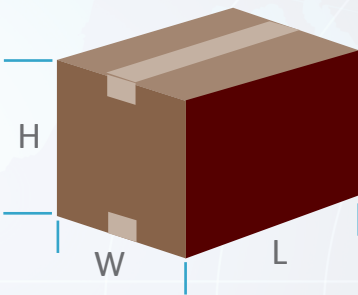

	Min	Max
L:	120	∞
W:	150	500
H:	130	500

Specifications

Model:	CT20U
Tape width:	37.5mm (1.5") or 50mm (2")
Belt speed:	23mtr per minute (9-20 cartons/min)
Carton capacity:	Length = 120mm - ∞ Width = 140 - 500mm Height = 120- 500mm
Power supply:	240V, 50Hz 1-phase
Power consumption:	450W
Machine dimensions:	1637 x 754 x 1375mm (L x W x H)
Machine nett weight:	153kg

Options

- > 3" taping head
- > Safety guard

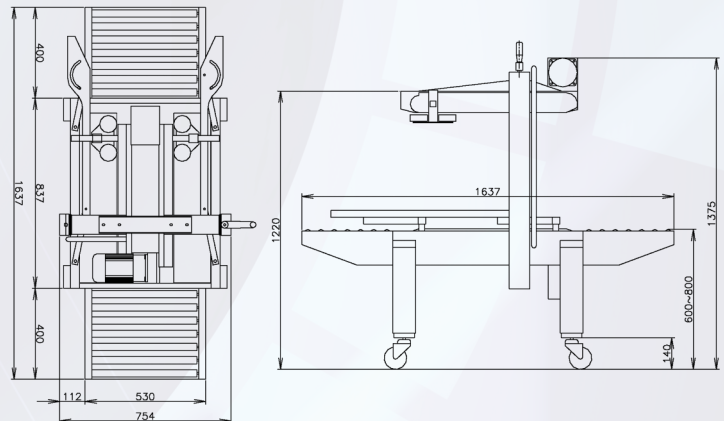

For more information on the complete range of Optimax® packaging products, please contact your authorised Optimax® distributor or visit:

www.optimaxproducts.com

©Copyright Optimax 2015
We reserve the right to change product specifications without prior notice
Re-order Code: LIT-PSPO16